

DigiFlow 6000R, Flow Totalizer and Multi-Filter Monitor

SAVANT ELECTRONICS INC.

2088-3, Sec 1., Huanzhong road, Taichung 40761, Taiwan

Tel : 886 4 2425 5578 Fax : 886 4 2425 0396

Email : savantco@ms65.hinet.net

Website : www.digisavant.com

Features :

- Flow volume totalized up to 99500 liters
- Programmable up to 5 filter capacity monitoring
- End of filter life alert
- Battery operated, 2 AAA batteries
- Automatic data memorized when battery power is off



Application :

- ✓ Under sink water treatment system
- ✓ Counter top water treatment system
- ✓ Commercial water treatment system
- ✓ Water dispenser

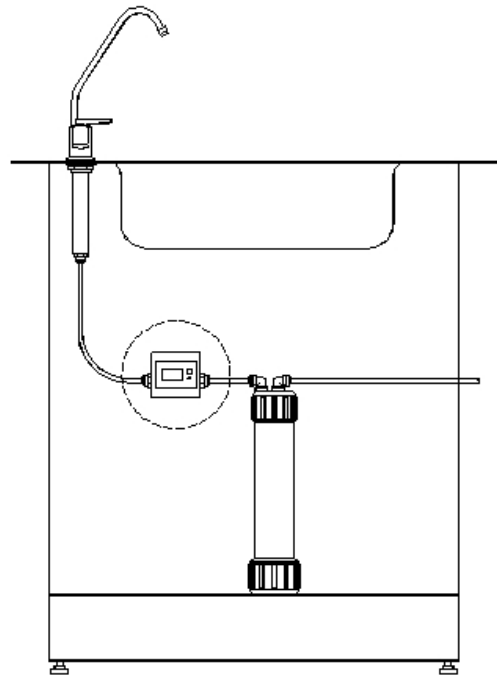

1.0 Electrical :

Operating Voltage : 3 DC Volts

Operating Current : 1.0 mA (work), 0.015 mA (sleep)

2.0 Mechanic :

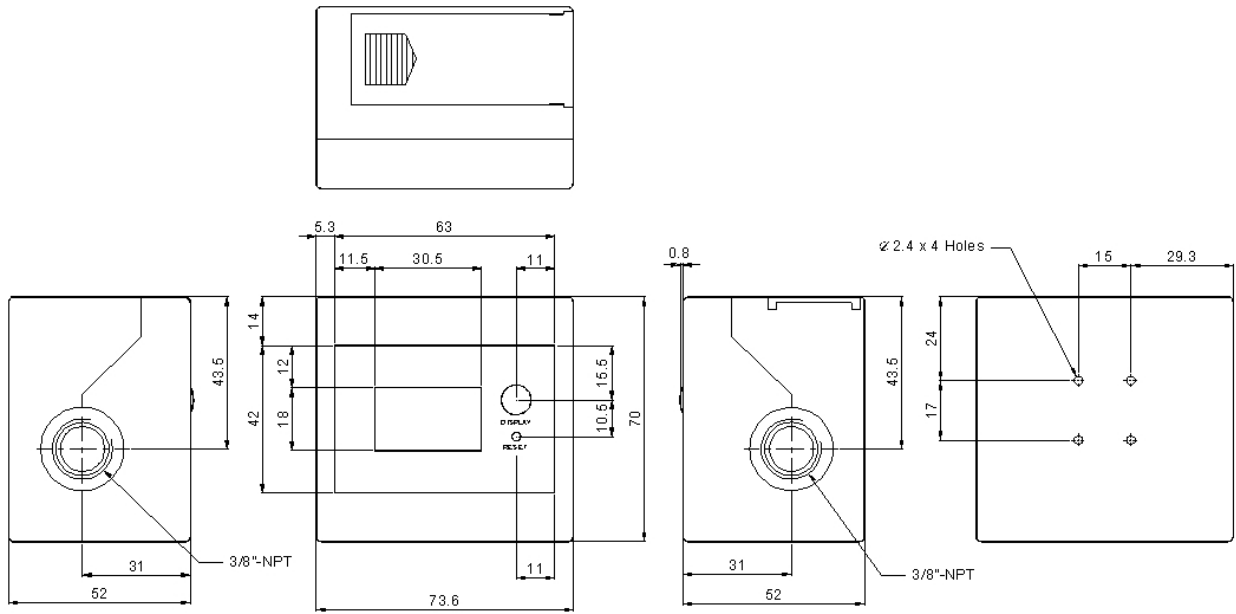

3.0 Application :

Mounting Method : Back Mount

Flowing Direction : Bi-Direction

Flow Rate : 1.2-12 liter/minute

Right to Left

or

Left to Right

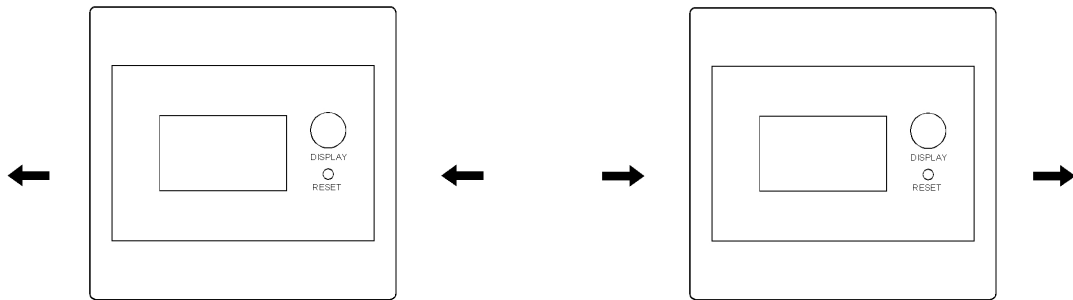

4.0 General :

Temperature : 0 to 40°C (32 to 104°F)

Pressure : Max.6.0 bar (85 psi)

Weight : 140 g (5.38 oz)

Accuracy : +/- 7%

Connection : 3/8 inch NPT Female

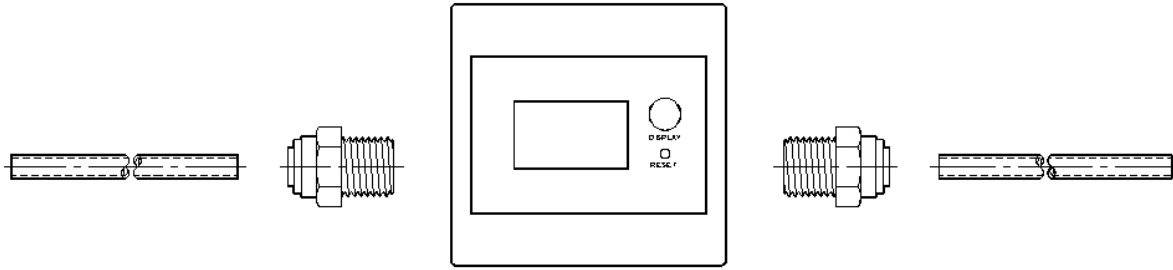

Materials : Sensor Body : Acetal Copolymer(POM), TICONA M90

Turbine : Acetal Copolymer(POM), TICONA M90

Stick of Turbine : #304 Stainless Steel

O-Ring : EPDM Rubber

Housing : ABS resin

5.0 Operation Guide

5.1 Install Batteries

Slide off the cover case of the battery room, and put into 2 AAA alkaline batteries. Then slide the cover case back. The battery power lasts more than 18 month for 30 liters daily use.

5.2 Connect Fitting

The specification of the DigiFlow 6000R connectors is 3/8” NPT female. The fitting should come with 3/8” NPT male thread.

5.3 Program Each Filter Capacity

Keep pressing DISPLAY button, then press RESET button, and then release both of the buttons. The LCD blinks “FLT 1” four times, then blinks “ OFF” to notify that the programming procedure is starting. Pressing DISPLAY button to choose the right capacity value. The sequence is OFF - 0 –500 – 1000 --- 99500 – OFF – 0 – 500. After choose right capacity value, press RESET button to save it.

* If the capacity value is chosen as “OFF”, the monitoring function of the specific filter will be disable.

5.4 Operating

The DigiFlow 6000R automatically turns on and display total flowing volume when there is water flowing through it. It automatically turns off in 10 seconds when there is no water flowing.

5.5 Check Filter Remaining Capacity

When the DigiFlow 6000R turns on, then press DISPLAY button could check the remaining capacity of each filter. The LCD blinks each filter and remaining capacity in sequence. For example, “FLT 1”, then

“ 988 ltr”, then “ FLT 2”, then “1877 ltr” After display all remaining capacity of each filter, the DigiFlow 6000R goes back to display the total flowing volume.

5.6 End of Filter Capacity Alert

When there is any filter remaining capacity reaches zero, the buzzer generates two short beep sound And the LCD blinks the specific filter to notify user. Like blinking “ FLT 2” .

5.7 Reset

After replace the specific filter cartridge, press RESET button to release the alert status, and reset the remaining capacity of the specific filter to be the original programmed capacity value.

5.8 Low Battery Power Alert

When the battery power is lower than normal working level, the buzzer generates two short beep sound and the battery symbol on the LCD corner blinks to notify user. Once the batteries are replaced, the alert status is released. The last status data is memorized and stored back when batteries go back to normal power level.